

## Model 1005 Whirlpool

The Model 1005 Whirlpool is designed to give immersion hydrotherapy to the arms and leg of a patient. It features a stationary therapy tank with fill and drain components, a Model 100 Turbine to generate a therapeutic flow of water, and a thermometer to measure the temperature of the water. The whirlpool is U.L./C.U.L. Listed.

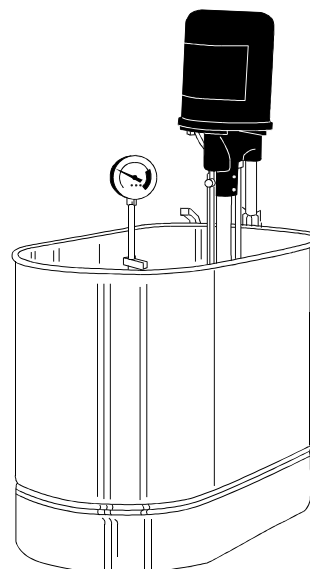

### Tank

The tank is made of 18 gauge Type 304 stainless steel which is formed, welded, and finished into a seamless unit. It has a beaded rim, vertical walls with embossed marks at 10-gallon intervals, and a coved reinforced bottom.

Water fills the tank through an over-the-rim inlet to prevent backflow. A drain on the tank wall prevents overflow. Water empties from the tank by gravity through a drain in the tank bottom. Drainage is controlled by a manually operated valve on the outside wall of the tank.

### Thermometer

The thermometer is a sanitary, solid-stem bimetal type with a 3" dial. It is mounted inside the tank, and has a dial range of 40°F to 140°F (5°C to 60°C).

### Turbines

The turbine is powered by a 1/3 hp, 3450 rpm electric motor having sealed bearings and thermal overload protection. The motor is connected by a stainless steel shaft to a nylon impeller. The shaft runs inside of a support tube, and is stabilized by a water-lubricated bearing.

An aerator tube injects air into the output stream from the impeller. The shaft-support tube and the aerator tube each have a portal for disinfecting the internal surfaces of the impeller and the aerator.

A manual valve on the impeller-housing inlet controls the impeller output from 0 to 45 gal/min. A manual valve on the aerator tube controls how much air is injected into the output stream.

The turbine mounts on a gas cylinder telescoping post at one end of the tank. A friction clamp on the post controls vertical positioning. A plug on the turbine supply cord plugs into a receptacle provided by the user.

### Optional Accessories

- Mixing Valves & Consoles
- Patient Chairs
- Patient Lifts & Carriers
- Patient Seats & Supports
- Tank & Turbine Products
- GFCI Plug

